

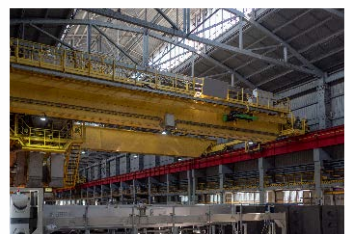

**ALTEST**<sup>®</sup>  
ALUMINIUM EXTRUSION INDUSTRY

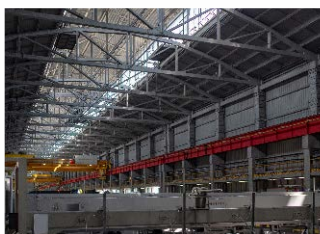

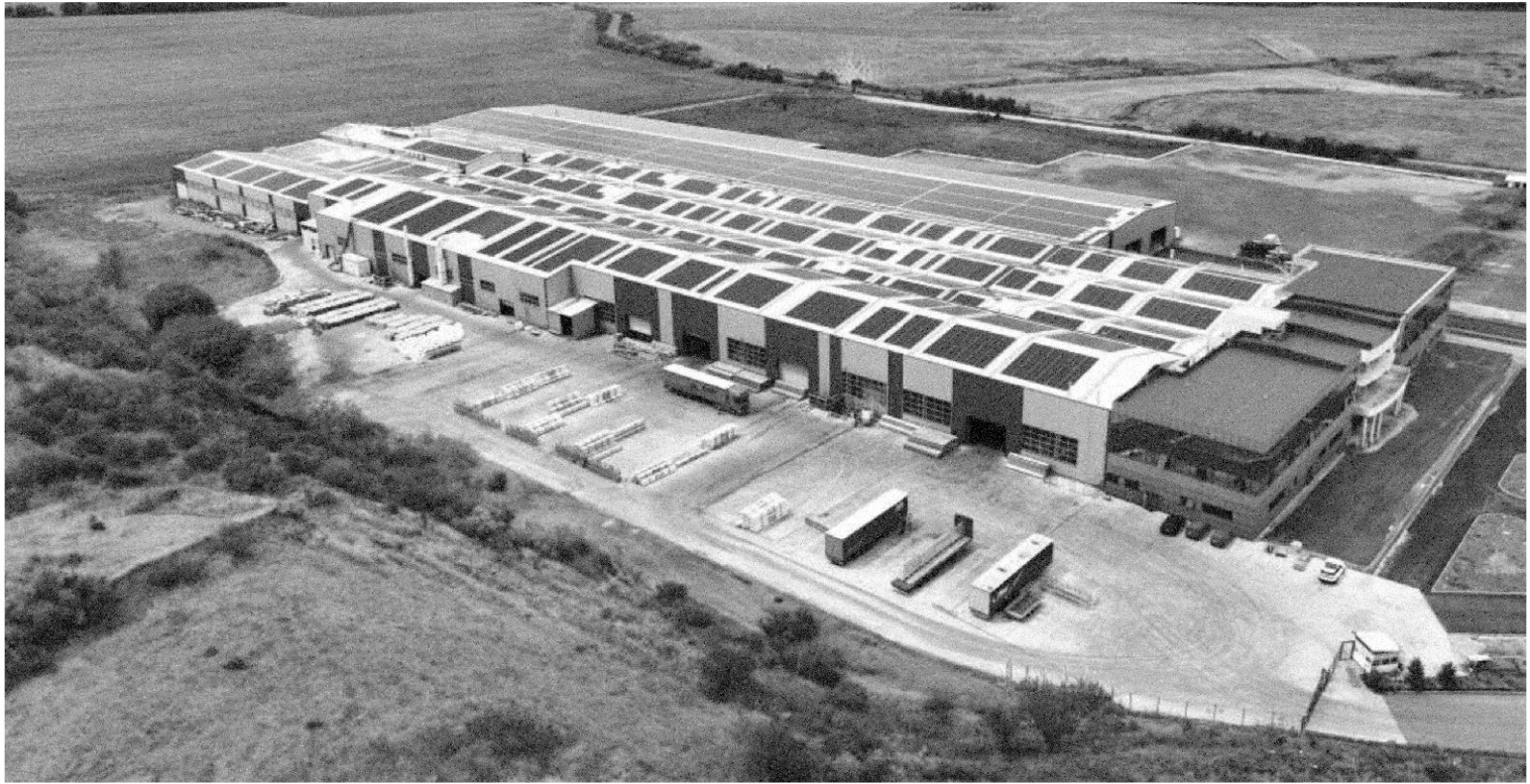









**Industrial Profiles**  
CUSTOM DESIGNED PROFILES



ALTEST GROUP, founded in 1992 in Burgas, Bulgaria, is a leading manufacturer of aluminium and PVC profiles. With a 100,000 square meter facility, the company handles the entire production process, from extrusion to distribution. Since 2000, ALTEST has expanded into providing complete architectural systems, establishing itself as a key player in the Balkans and globally.

The company's success is driven by a team of over 650 specialists. ALTEST holds several ISO certifications and has received numerous awards, including the Golden Trophy for Quality Award of Excellence. Innovation is central to ALTEST's strategy, with 3% of its annual turnover invested in Research & Development. The company produces complex aluminium products for various industries using state-of-the-art, energy-efficient machinery.

ALTEST GROUP is committed to ethics and sustainability, focusing on employee training, recycling, and renewable energy to support a circular economy and a better future for the community.

 Industrial facilities:	<b>140.000</b> sq.m.
 2 Aluminium Extrusion Lines	
 1 Vertical Powder Coating Line	
 1 Horizontal Powder Coating Line	
 1 Anodizing Plant	
 1 Thermal Break Assembly Line	
 2 Sublimations Lines	
 Surface Treatment Machines	
 Machining Site	
<hr/>	
 Production capacity:	
 Surface treatments – Anodizing:	<b>17.000</b> m <sup>2</sup> /annually
	<b>1.000</b> t/annually
 Surface treatments – Powder coating:	<b>3.300.000</b> m <sup>2</sup> /annually
	<b>6.500</b> t/annually
 Profile size production capacity:	Up to <b>7.000</b> mm length

# Industrial Profiles

CUSTOM DESIGNED PROFILES

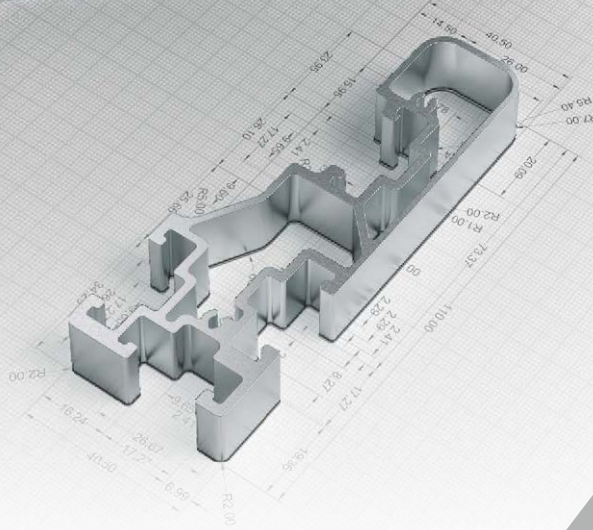
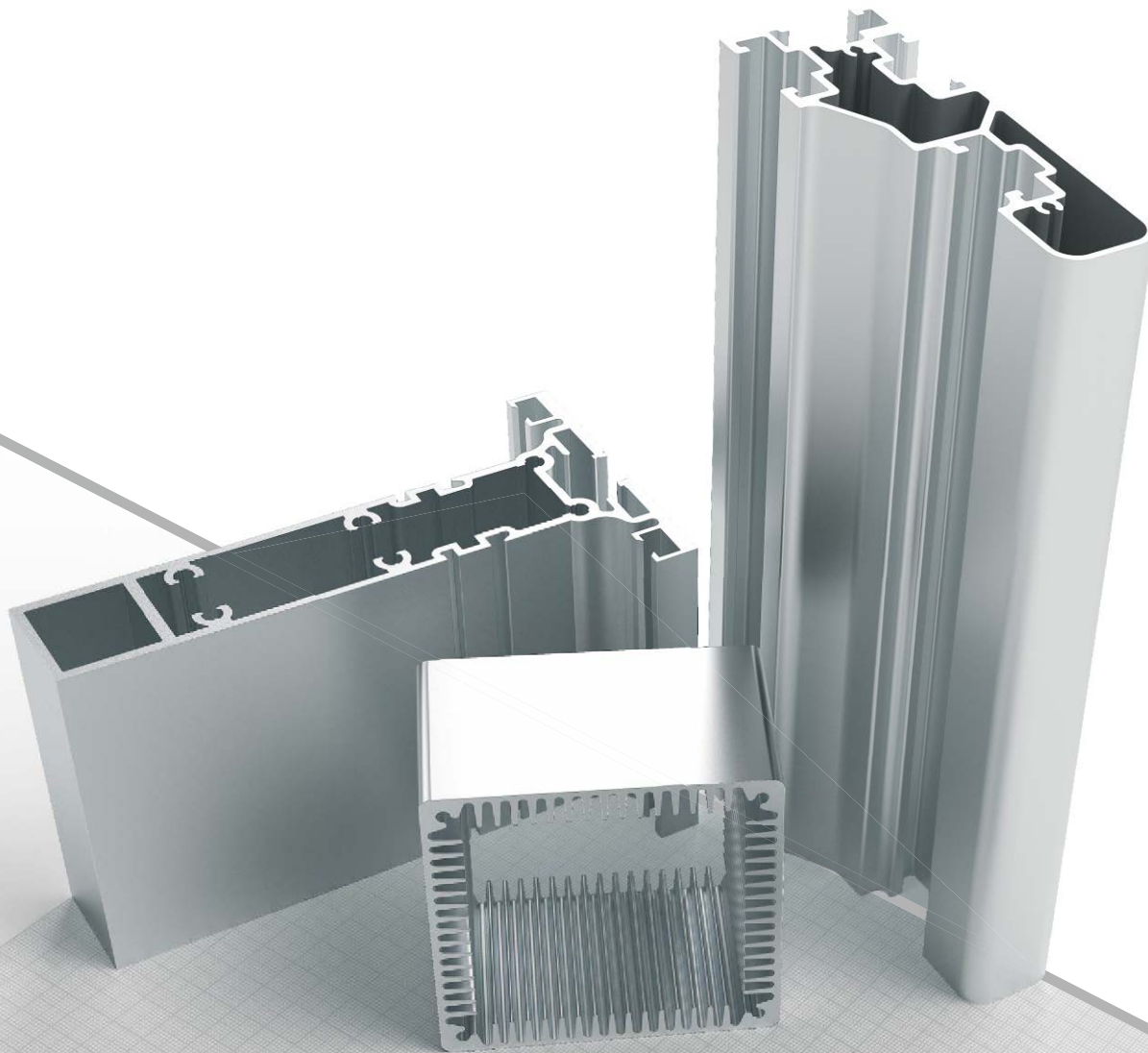

The industrial profile business unit is a key factor in establishing ALTEST as a leader in the aluminium industry. ALTEST's Research and Development Division is composed of a highly skilled team of engineers responsible for designing, developing, and integrating products into the production process to meet the demands of its most discerning clients. ALTEST leverages advanced technology and flexible manufacturing, along with the expertise of its experienced workforce, to produce specialized aluminum profiles. These profiles are designed to meet the demands of industries that require cutting-edge and innovative solutions. A dedicated Quality Control department conducts rigorous daily testing throughout the entire production process, ensuring the highest standards of product quality.

Products of the brand Altest are valued on national and international level and they are certified based on ISO:



**Altest CE marking:**

Conformité Européenne (CE) certification is a regulatory standard that verifies certain products are safe for sale and use in the European Economic Area



**Altest Performance Certificates:**

In our company, every aluminum system, new or existing, comes with the necessary performance certificates. Our ongoing collaboration with globally recognized institutes gives us a competitive edge, ensuring our products consistently improve the end user's quality of life.



**Altest Qualanod Certificate:**

Certificate for the anodic oxidation of aluminium profiles.



**Altest Qualicoat Certificate:**

Quality Certificate for aluminium profile coatings.



**Altest ISO 9001:2015:**

Design, manufacture and sale of aluminum extruded profiles and architectural systems.

# Industrial Profiles

CUSTOM DESIGNED PROFILES



## Aluminium properties

Aluminium boasts a unique and unmatched set of properties, making it an incredibly versatile, highly practical, and attractive construction material.

### **Weight**

Aluminium is lightweight, with a density that is just one-third of steel.

### **Strength**

Depending on the alloy and manufacturing process, aluminium has a tensile strength ranging from 70 to 700 MPa. Properly designed and alloyed extrusions can be as strong as structural steel.

### **Elasticity**

Aluminium has a Young's modulus of about one-third that of steel ( $E = 70,000$  MPa). This means that an aluminium extrusion needs a moment of inertia three times greater than a steel profile to achieve the same level of deflection.

### **Linear Expansion**

Aluminium has a relatively high coefficient of linear expansion compared to other metals, which should be considered in the design phase to account for expansion differences.

### **Formability**

Aluminium is highly formable, a quality that is extensively utilized in the extrusion process. It can also be cast, drawn, and milled with ease.

### **Reflectivity**

Aluminium is an effective reflector of both light and heat.

### **Machining**

Aluminium is very easy to machine using standard equipment like saws and drills. It is also suitable for forming in both hot and cold conditions.

### **Joining**

Aluminium can be joined by all common methods, including welding, soldering, adhesive bonding, and riveting.

### **Corrosion Resistance**

When exposed to air, aluminium forms a thin oxide layer that provides excellent protection against corrosion, even in harsh environments. This layer can be further enhanced with surface treatments like anodising or powder coating.

### **Conductivity**

Aluminium has excellent thermal and electrical conductivity, rivaling that of copper. Additionally, an aluminium conductor weighs half as much as an equivalent copper conductor.

### **Non-toxic**

Aluminium is non-toxic, making it ideal for food preparation and storage.

# Industrial Profiles

CUSTOM DESIGNED PROFILES

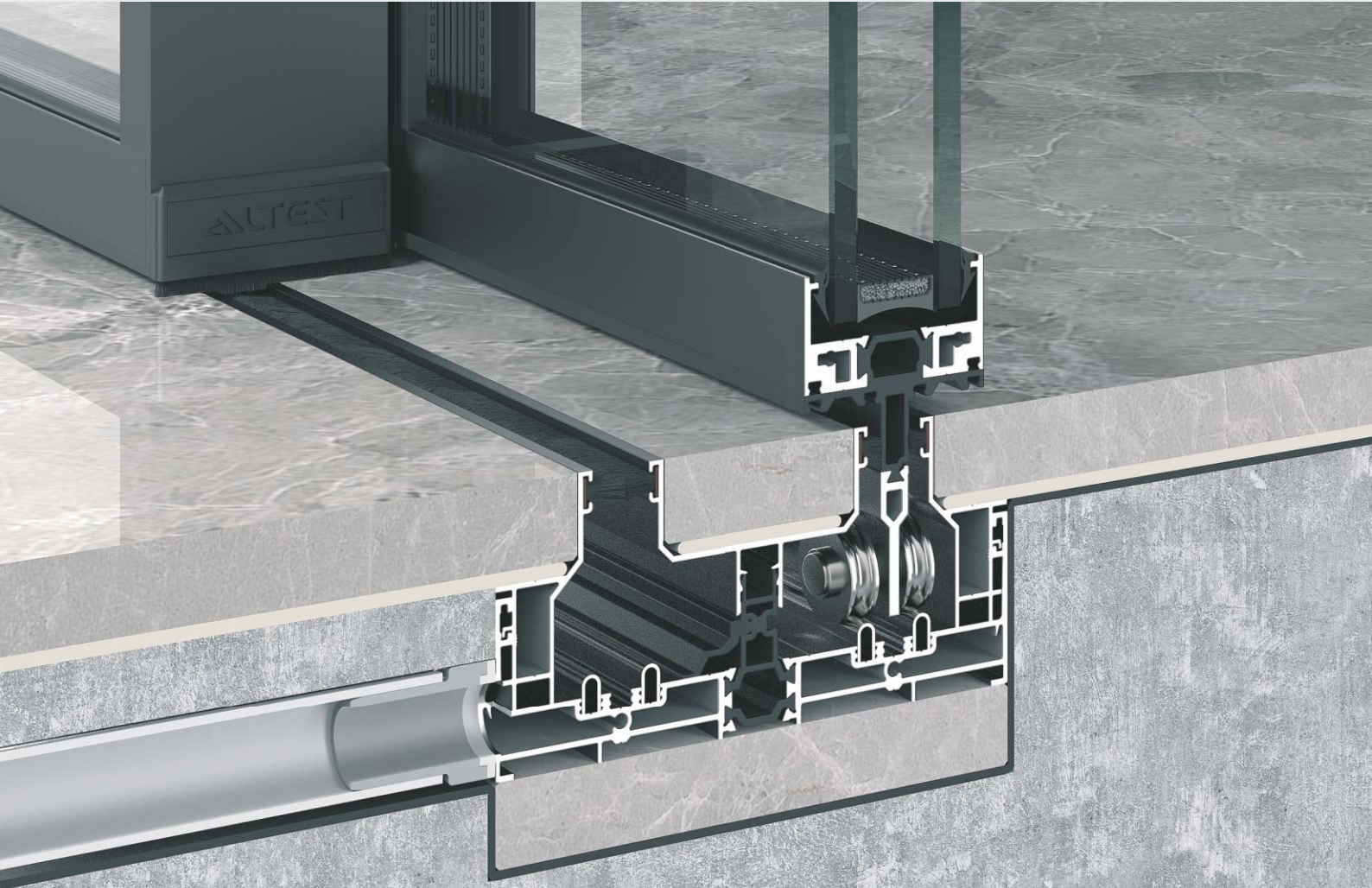
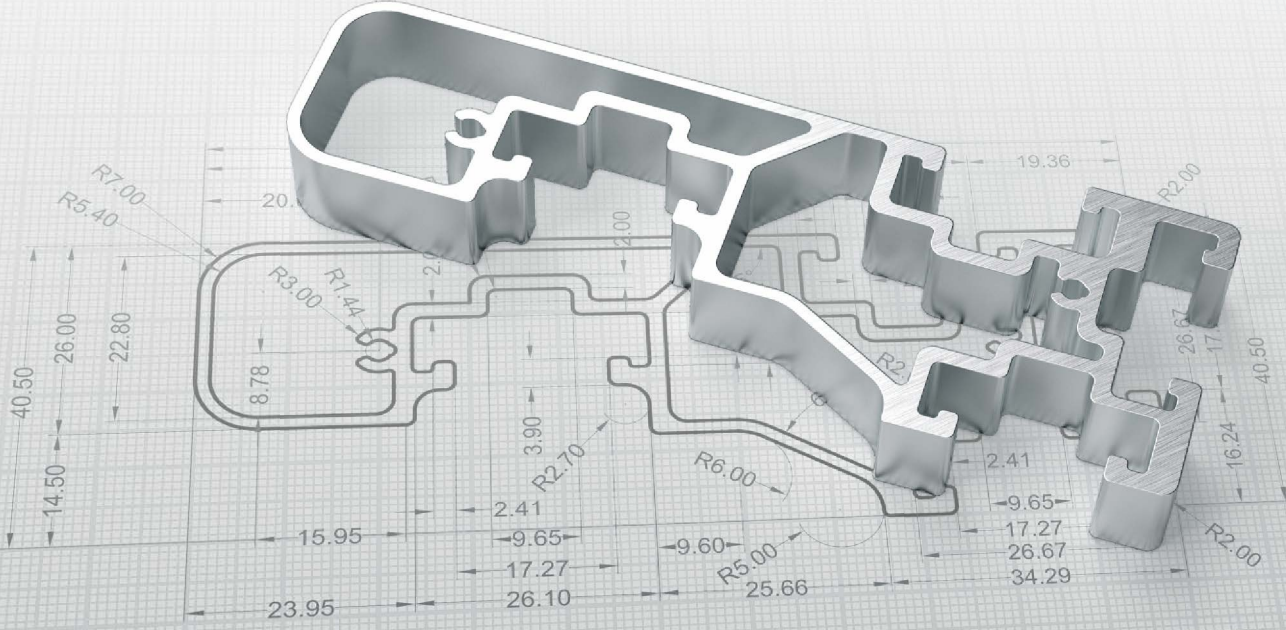



## Products

### Industrial Profiles

ALTEST manufactures industrial profiles tailored to client specifications, providing solutions across various sectors, including construction, transportation, engineering, the automotive industry, and electrical applications. The dedicated production unit for these profiles ensures products of the highest quality, characterized by:

- ▲ Precision in Sizing
- ▲ High-Quality Coatings
- ▲ Smooth, Polished, Grinded, Brushed surfaces
- ▲ Mechanical Processing of Aluminium Profiles
- ▲ Anodization and Specialized Cutting
- ▲ Customized Packaging
- ▲ Compliance with ISO Standards

### Aluminium Systems

ALTEST offers a comprehensive range of both conventional and heat-insulating aluminium systems, along with specialized constructions such as glass walls, atriums, and transition bridges. These products are distinguished by the following features:

- ▲ Diverse Product Selection
- ▲ High-Level Construction Quality
- ▲ Outstanding Design
- ▲ Certification from Internationally Accredited Institutes

## EN-AW Chemical composition

### Alloy designation

Specifications	Numerical	Chemical symbols	<b>Si</b>	<b>Fe</b>	<b>Cu</b>	<b>Mn</b>	<b>Mg</b>	<b>Cr</b>	<b>Zn</b>	<b>Ti</b>	Residuals
			min-max	min-max	min-max	min-max	min-max	min-max	min-max	min-max	
EN 573-3	<b>EN AW-6060</b>	AlMgSi	0,3-0,6	0,1-0,3	0,1	0,1	0,35-0,6	0,05	0,15	0,1	0,15
EN 573-3	<b>EN AW-6063</b>	AlMg0,7Si	0,2-0,6	0,35	0,1	0,1	0,45-0,9	0,1	0,1	0,1	0,15
EN 573-3	<b>EN AW-6005</b>	AlSiMg	0,6-0,9	0,35	0,1	0,1	0,4-0,6	0,1	0,1	0,1	0,15
EN 573-3	<b>EN AW-6082</b>	AlSiMgMn	0,5-0,9	0,35	0,3	0,5	0,4-0,7	0,3	0,2	0,1	0,15
EN 573-3	<b>EN AW-6463</b>	AlMg0,7Si(B)	0,2-0,6	0,15	0,2	0,5	0,45-0,9	0,25	0,05	0,1	0,15

### Tempers according to EN 755-2:2010

Symbol	Description
<b>T4</b>	Solution heat - treated and then naturally aged
<b>T5</b>	Cooled from an elevated temperature shaping process and then artificially aged
<b>T6</b>	Solution heat - treated and then artificially aged
<b>T66</b>	Solution heat - treated and then artificially aged - mechanical property level higher than T6 achieved through special control of the process 6000 series alloys
<b>F22</b>	The F22 grade is a low-alloy steel, and it is very deep-hardening and heat-treatable

ALTEST in collaboration with the customer, has the expertise to manage the process between T4 and F22/F28 (DIN STANDARD) in order to meet and serve specific requirements with respect to all customer requirements - technical specifications of the final construction (bending facilitation, corrosion resistance and electrical conductivity improvement).

If a profile cross section is comprised of different thickness which fall in more than one set of specified mechanical property values, the lowest specified value shall be considered as valid for the whole profile cross section.

The hardness values are only typical and shall not be considered as minimum.

### Tolerances on dimensions and form

Alloy	EN Standard
<b>EN AW 6060</b>	<b>755 - 9 / 12020 - 2</b>
<b>EN AW 6063</b>	<b>755 - 9 / 12020 - 2</b>
<b>EN AW 6005 / 6005A</b>	<b>755 - 9</b>
<b>EN AW 6082</b>	<b>755 - 9</b>

## Mechanical Properties

Alloy	Temper	Diameter (D)	Square Restangular Width (s)	R <sub>m</sub> min Mpa	Rp <sub>0,2</sub> min Mpa	A %	A <sub>50</sub> mm	Hardness [HB]	
<b>EN AW-6060 AlMgSi</b> Extruded Tubes Profiles 755 - 2	Profiles	wall thickness							
	<b>T4</b>	≤25		120	60	16	14	50	
	<b>T5</b>	≤5		160	120	8	6	60	
		5<e≤25		140	100	8	6	60	
	<b>T6</b>	≤3		190	150	8	6		
		3<e≤25		170	140	8	6	70	
	<b>T64</b>	≤15		180	120	12	10		
	<b>T66</b>	≤3		215	160	8	6	75	
		3<e≤25		195	150	8	6		
	Tubes								
	<b>T4</b>	≤15		120	60	16	14	50	
	<b>T5</b>	≤15		160	120	8	6	60	
	<b>T6</b>	≤15		190	150	8	6	70	
	<b>T64</b>	≤15		180	120	12	10	60	
	<b>T66</b>	≤15		215	160	8	6	50	
	<b>EN AW-6063 AlMg0,7Si</b> Extruded Tubes Profiles 755 - 2	Profiles	wall thickness						
<b>T4</b>		≤25		130	65	14	12	50	
<b>T5</b>		≤3		175	130	8	6	65	
		2<e≤25		160	110	7	5	65	
<b>T6</b>		≤10		215	170	8	6	75	
		10<e≤25		195	160	8	6	75	
<b>T64</b>		≤15		180	120	12	10	65	
<b>T66</b>		≤10		245	200	8	6	80	
		10<e≤25		225	180	8	6	80	
Tubes									
<b>T4</b>		≤10		130	65	14	12	55	
		10<e≤25		120	65	12	10	55	
<b>T5</b>		≤25		175	130	8	6	65	
<b>T6</b>		≤25		215	170	10	8	75	
<b>T66</b>		≤25		245	200	10	8	80	
<b>EN AW-6005 AlSiMg</b> Extruded Tubes Profiles 755 - 2		Profiles	wall thickness						
	Open								
	<b>T4</b>	≤25		180	90	15	13	50	
		≤5		270	225	8	6	90	
	<b>T6</b>	5<e≤10		260	215	8	6	85	
		10<e≤25		250	200	8	6	85	
	Hollow								
	<b>T4</b>	≤10		180	90	15	13	50	
		≤5		255	215	8	6	85	
	<b>T6</b>	5<e≤15		250	200	8	6	85	
	Tubes								
	<b>T6</b>	≤5		270	225	8	6	90	
		5<e≤10		260	215	8	6	85	
	<b>EN AW-6082 AlSiMgMn</b> Profiles 755 - 2	Profiles / Tubes	wall thickness						
			Open	Hollow					
<b>T4</b>		≤25		205	110	14	12	70	
		≤5		270	230	8	6	90	
<b>T5</b>		≤5		290	250	8	6	95	
		5<e≤25		310	260	10	8	95	

## Extruded alloys and tempers

### General alloy natural properties

The 6000 series has good extrudability and can be solution heat treated at the extrusion temperature. Furthermore, these alloys have medium to high strength, are easy to weld and offer good resistance to corrosion, even in marine environments. The bulk of the extruded material for load bearing constructions is made from these qualities. They are used for load bearing constructions both on land and at sea.

---

#### **EN AW-6060** AlMgSi Composition: Al 0,5Mg 0,5Si Fe

---

##### Applications:

Architectural sections for windows, doors, curtain walls. Interior fitting, frame system, lighting, ladders, railings, fences. Heat sink sections, electronic modules, electro motor housings. Flexible assembly systems, special machinery elements. Truck and trailer flooring, pneumatic installation, railway, inside applications. Irrigation, heating and cooling pipes. Furniture, office equipment.

##### Characteristic properties:

Very good corrosion resistance. Very good weldability. Good cold formability especially in temper T4. Medium fatigue strength. Commonly used alloy for very complex cross sections. Standard decorative anodizing quality.

##### Product Forms:

Bar, Profile section shape, Rod, Slugs impacts, Tube, Wire

---

#### **EN AW-6063** AlMg0,7Si Composition: Al 0,7Mg 0,4Si

---

##### Applications:

Architectural sections for windows, doors, curtain walls. Interior fittings, frame systems, lighting, ladders, railings etc. Heat sink sections, electronic modules, electro motor housings. Flexible assembly systems, special machinery elements; Truck and trailer flooring, pneumatic installation, railway, inside applications. Irrigation pipes. Furniture, office equipment. Radiator and other heat exchanger applications.

##### Characteristic properties:

Very good corrosion resistance. Very good weldability. Medium strength heat treatable alloy. Medium fatigue strength. Good cold formability especially in temper T4. Suitable for very complex cross sections. Standard decorative anodizing quality.

##### Product Forms:

Bar, Profile section shape, Rod, Slugs impacts, Sheet, Tube, Wire.

---

#### **EN AW-6082** AlSiMgMn Composition: Al 0,9Mg 1,0Si 0,7Mn

---

##### Applications:

Heavy duty structures in rail coaches, truck frames, ship building, offshore, bridges, military bridges, bicycles, boilermaking. Machinery: platforms, flanges, hydraulic systems, mining equipment, pylons and towers, motorboats. Nuclear technology. Masts and beams for ship building (especially for sweet water). Tubes for scaffolding, framework for tents and halls, piping, tubing Screw machine products. Rivets.

##### Characteristic properties:

Very good corrosion resistance. Very good weldability (lowered strength values in the zone of welding). Good machinability. Good cold formability in T4 temper after a stabilizing heat treatment. Heat treatable medium high strength construction. Alloy with a strength somewhat higher than 6061. Medium high fatigue strength. Not suitable for complex sections.

##### Product Forms:

Bar, Forging, Profile section shape, Plate, Slugs impacts, Sheet, Tube, Wire

## Special alloy natural properties

	Elastic			Physical							
	Modulus of elasticity	Modulus of rigidity	Poisson's ratio	Solidus temperature	Liquidus temperature	Specific heat capacity	Coefficient of thermal expansion	Density Resistivity	Thermal conductivity	Electrical conductivity	
	<i>E</i> Mpa	<i>G</i> Mpa	<i>ν</i>	<i>T<sub>sol</sub></i> °C	<i>T<sub>liq</sub></i> °C	<i>C<sub>p</sub></i> J kg <sup>-1</sup> K <sup>-1</sup>	<i>α</i> μm m <sup>-1</sup> K <sup>-1</sup>	<i>ρ</i> kg m <sup>-3</sup>	<i>ρ<sub>el</sub></i> nΩ m	<i>λ</i> W m <sup>-1</sup> K <sup>-1</sup>	<i>EC</i> %IACS
<b>EN AW-6060</b> Al MgSi											
O	69500	26100	0.33	610	655	898	23.4	2700	35	195	49.5
T1	69500	26100	0.33	610	655	898	23.4	2700	36	187	48
T4	69500	26100	0.33	610	655	898	23.4	2700	32	209	54
T5	69500	26100	0.33	610	655	898	23.4	2700	32	209	54
T6	69500	26100	0.33	610	655	898	23.4	2700			
<b>EN AW-6063</b> Al Mg0,7Si											
O	69500	26100	0.33	615	655	898	23.5	2700	30	218	57.5
T1	69500	26100	0.33	615	655	898	23.5	2700	34	193	50.5
T4	69500	26100	0.33	615	655	898	23.5	2700	35	197	9.5
T5	69500	26100	0.33	615	655	898	23.5	2700	31	209	55.5
T6	69500	26100	0.33	615	655	898	23.5	2700	33	201	52
<b>EN AW-6005</b> Al SiMg(A)											
T1	69500	26200	0.33	605	655	892	23.3	2710			
T4	69500	26200	0.33	605	655	892	23.3	2710			
T5	69500	26200	0.33	605	655	892	23.3	2710			
T6	69500	26200	0.33	605	655	892	23.3	2710	35	193	49.5
<b>EN AW-6082</b> Al Si1MgMn											
O	70000	26400	0.33	575	650	894	23.1	2710	31	216	55.5
T1	70000	26400	0.33	575	650	894	23.1	2710			
T4	70000	26400	0.33	575	650	894	23.1	2710	41	187	42
T5	70000	26400	0.33	575	650	894	23.1	2710			
T6	70000	26400	0.33	575	650	894	23.1	2710	39	172	44

## Profile size production capacity

Open profiles dimensions: min 8 mm, max 220 mm  
 Closed profiles dimensions: min 10 mm, max 220 mm  
 Weight per meter: min 0,05 kg / m, max 10 kg / m  
 Profiles Length: 10 mm – 7.000 mm ( Standard 6.000 mm)

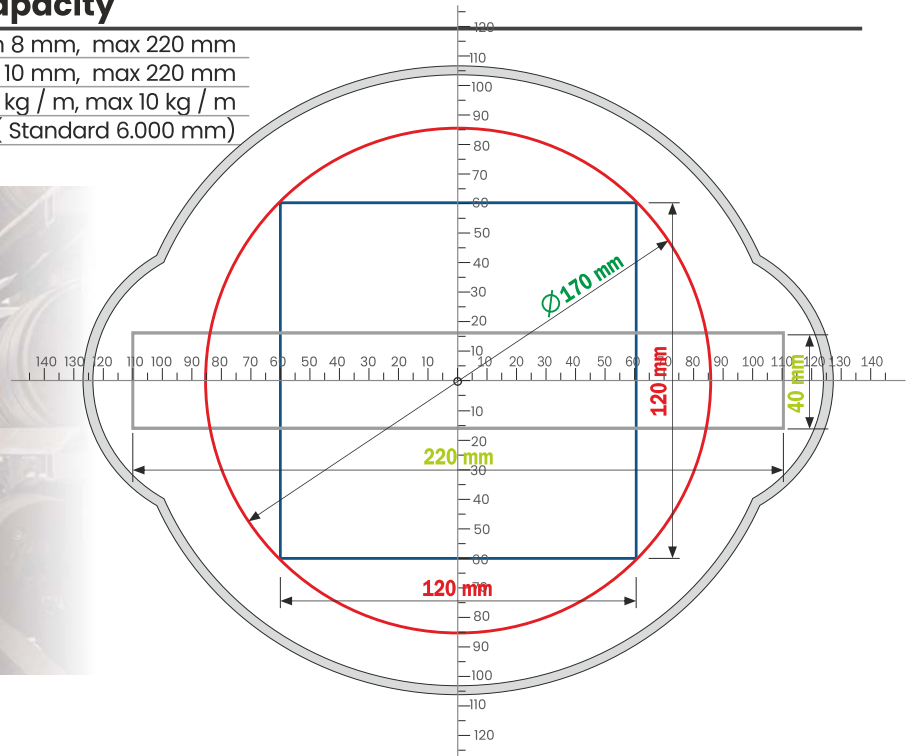

## Aluminium profiles application

Aluminum, thanks to its unique properties and characteristics as a metal, combined with the highly specialized expertise and unmatched production capabilities of the ALTEST Industrial Profile Business Unit, can be utilized across various fields and in unlimited applications, including:

- ▲ Photovoltaic Sub-constructions
- ▲ Automobile industry
- ▲ Measurement devices
- ▲ Fly screens
- ▲ Office furniture and office partition walls
- ▲ Garden furniture, metal furniture and sunshades
- ▲ Advertising signs
- ▲ Air shafts for air conditioning systems
- ▲ Aluminium rails
- ▲ Garage doors
- ▲ Heating boilers, heating furnace
- ▲ Lamps



## Logistics

Altest Group prides itself on maintaining seamless and efficient operations, bolstered by our in-house logistics company. With a fleet of 25 trucks, we are fully equipped to deliver our goods reliably across both Western and Eastern Europe, ensuring timely distribution and consistent service to all our clients.

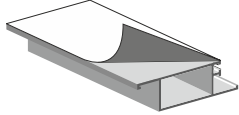
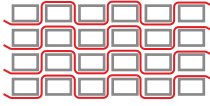
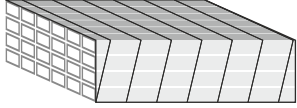
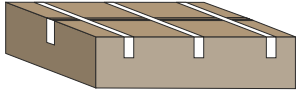
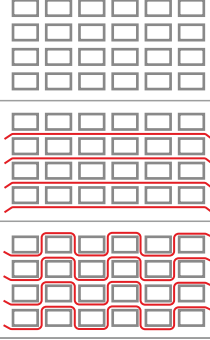
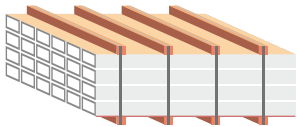
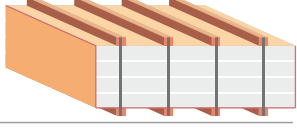
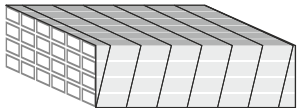

## Types of packaging

	Description	Variant N°	Material
<b>Adhesive protection tape</b>			
	Protection of profile over the surface	<b>A1</b>	Machine Every profile with protective tape "ALTEST"
		<b>A2</b>	Machine Every profile with customer's protective tape
		<b>A3</b>	No protective tape (ex. MF Profiles)
<b>Packet</b>			
	Internal organization of profiles inside a packet	<b>I1</b>	With paper/nylon between each profile
		<b>I2</b>	Without separator
 	Outside packet wrapping	<b>O1</b>	Nylon
		<b>O2</b>	Stretch
		<b>O3</b>	Crepe paper
		<b>O4</b>	without outer packaging (stretched only at both ends)
		<b>O5</b>	Covered with cardboard box
<b>Bulk Profile organization</b>			
	Protection of profiles against rubbing	<b>S1</b>	Without separators on each row
		<b>S2.1</b>	With paper on each row
		<b>S2.2</b>	Perforated nylon on each row
<b>S3</b>	Paper/nylon between each profile		
<b>Pallet</b>			
  	Outer pallet variants	<b>P1.1</b>	Wooden pallet with customer's dimension
		<b>P1.2</b>	Standard wooden pallet - width 60cm
		<b>P2</b>	Bottom and top covered with cardboard sheets
<b>P3</b>	Fully stretched		



South Industrial Area  
T: +359 56 880440  
Burgas  
BULGARIA

[office@altest-kmg.com](mailto:office@altest-kmg.com)